

## PRODUCT SUBMITTAL - CORNERS & END DAMS

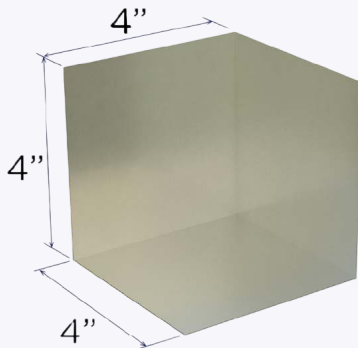
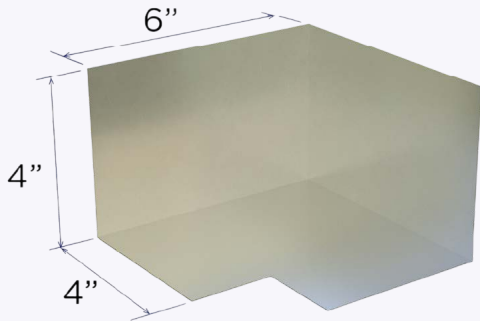
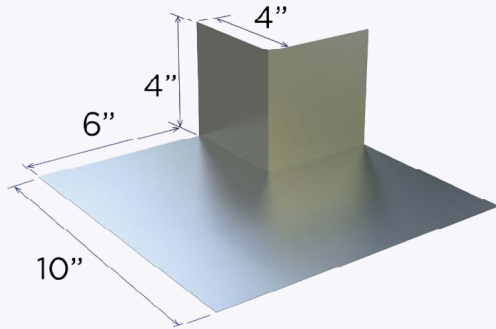

### Recycled Content:

Stainless Steel (Type 304)  
68% Post-Consumer  
18% Post-Industrial

### Material conformance:

3GEN Masonry Products, Inc.'s Prefabricated Stainless Steel Corners & End Dams are soldered to ensure durable inside corners, outside corners, and end dams.

They're designed to seamlessly integrate with all 3GEN Masonry Products, Inc. flashings, effortlessly positioning them beneath the flashing for superior defense against moisture infiltration.

Stainless Steel: Type 304 ASTM A240 / A240M,

ASTM A480 / A480M & ASTM A666.

### Sizes/Finishes:

Corners & End Dams: 26 gauge Thickness

Corners & End Dams: Stainless Steel (Type 304)

2 B / 2D Finish

Flashing Accessories:

End Dam

Outside Corner

Inside Corner

In order to email your submittal sheet information, you must have Adobe Acrobat installed on your computer.

### NOTE

The information provided herein is for general informational purposes only and does not constitute a professional opinion or engineering judgment. It is not intended to replace the design, detailing, or project-specific determinations of the licensed architect or engineer of record.

Each project is unique. The selection, application, suitability, and proper installation of these products are the sole responsibility of the design professional and installer based on project-specific conditions, substrate, exposure, and applicable codes.

All products and information referenced herein are subject to 3GEN Masonry Products, Inc.'s Terms and Conditions of Sale, including all limitations of liability, disclaimers of warranties, and exclusive remedies, as published and in effect at the time of sale.

### Mailing Address

8528 Davis Blvd., #134-246 North  
Richland Hills, TX 76182 Tel#:  
1-800-556-5785

**3genmp.com**

### Warehouse Address

8550 Parkway Drive Leeds,  
AL 35094 Tel#:  
1-800-556-5785