

PRODUCT SUBMITTAL - LADDER EYE

Ladder Eye Joint reinforcing is designed for embedment in the horizontal mortar joints of concrete masonry units.

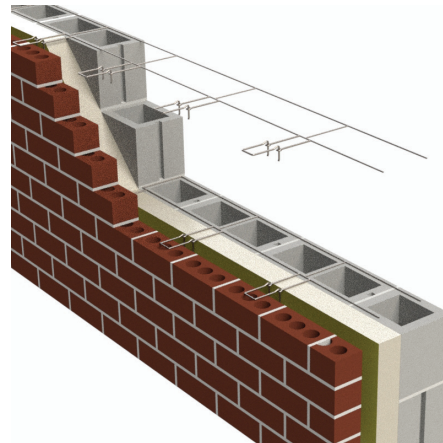
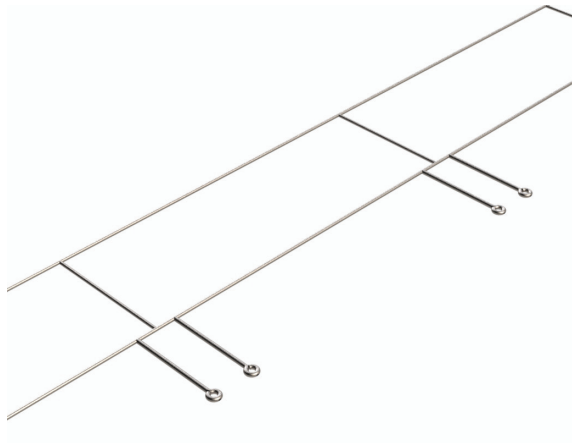

Recycled Content:

85% Post-Consumer 10% Post-Industrial

Material Conformance

Ladder Eye Joint reinforcing is designed for embedment in the horizontal mortar joints of concrete masonry units.

ASTM A951/A951M (Standard Specification for Steel Wire for Masonry Joint Reinforcing.)

Meets TMS 402/602 & ACI / ASCE 530 Building Code Requirements and Specification for Masonry Structures

Wire: (Carbon Steel) ASTM A1064 / A1064M

Tensile Strength: 80,000 psi. - Yield Point 70,000 psi.

Mill Galvanized ASTM A641 / ASTM A641M (0.1 oz/ft)

Hot Dip Galvanized after fabrication.

ASTM A153 / ASTM A153-B2 (1.5 oz/ft)

Product Details

Cross rods welded 16" o.c.

10 ft long pieces

Wire deformations meet ASTM A951

Structural Performance:

Capable of withstanding 100 lbs load in tension and compression without deforming or developing play in excess of .05 inch. (Test results available upon request)

Eye wire weld height will not exceed half the dimension of the mortar joint (3/8" joint = 3/16" max reinforcement). This meets TMS 402/602 Building Code Requirements and Specification for Masonry Structures.

Finish

Hot Dip Galvanized

Wire Diameter:

Standard

Side Rods

9 Gauge (.148")

Cross Rods

9 Gauge (.148")

CMU / Block Size:

4" 6" 8" 10" 12"

Insulation Thickness:

0" 1" 1 1/2" 2" 2 1/2" 3" 3 1/2" 4"

3/16" Diameter Hook (Pintle) Length:

3" 4" 5" 6" 7"

RESET EMAIL PRINT

NOTE

The information contained on this submittal sheet does not constitute any professional opinion or judgement and should not be used as a substitute for any architect or engineer professional determinations. Each construction project is unique and the use of these products is the responsibility of the architects, engineers and other professionals who are familiar with the specific design of the project.

Mailing Address
 8528 Davis Blvd., #134-246
 North Richland Hills, TX 76182
 Tel#: 1-800-556-5785

3genmp.com

Warehouse Address
 8550 Parkway Drive
 Leeds, AL 35094
 Tel#: 1-800-556-5785